

INSTRUCTIONS FOR BOWSER #100400 USRA MOUNTAIN KIT

These instructions provide photographs of completed model, exploded view drawings, diagrams, step-by-step instructions and an itemized parts list. If for reasons beyond our control, any shortage or faulty part is found, write directly to the manufacturer, including name of your dealer and date of purchase. Return any defective parts for exchange. The builder should study the instructions and drawings to attain a working knowledge of proper procedure. Assembly work should be in sequence outlined in this manual to assure proper construction. We have included some extra parts in case you misplace or drop them on the floor. DO NOT RUN THE MECHANISM OR ENGINE UPSIDE DOWN.

TOOLS

This is a builders kit, you will need a few tools. You will find use for the following: small hammer, several assorted pattern files, jewelers screwdriver (a set is convenient), a 6" flat file with a fairly fine cut, knife, pliers, flush cut nippers like Mascot #413 and tweezers.

BEFORE PAINTING YOUR MODEL OR DETAIL THE BOILER, WE RECOMMEND THAT YOU BUILD THE COMPLETE MECHANISM ATTACH THE UNDECORATED BODY AND THOROUGHLY TRACK TEST IT.

STEP #1

Clean flash from frames.

CLEAN ALL FLASH FROM EDGES OF BEARING SLOTS OF UNDERFRAME AND COVER PLATE WHERE SHOWN AS DARK LINES & SHADED AREAS.

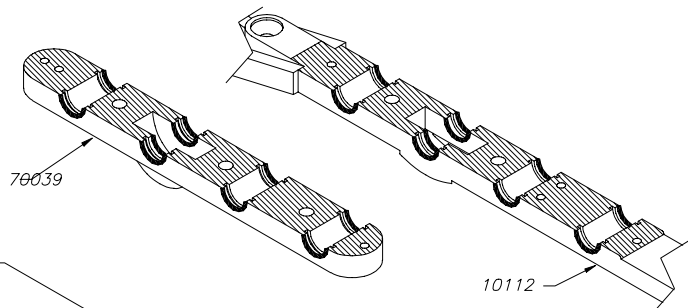

STEP #2

Assemble draw bar as shown.

Subkit 100403

FULL SIZE



256



1134



256183



3703



27



8451

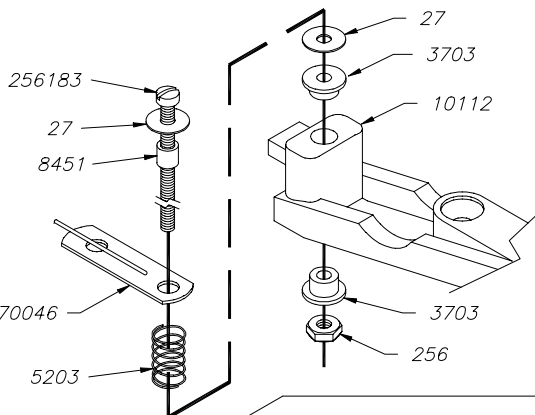

STEP #3

Clean flash from edges of parts. File mating surfaces on a flat file. Check to see that the frame is straight. Assemble the drivers with insulated wheels on the left side of the frame as shown. Assure the wheels spin freely. Oil lightly. See Step 3a for method of loosening wheels.

Subkit 100403

FULL SIZE



256061



256031



440032



27



256

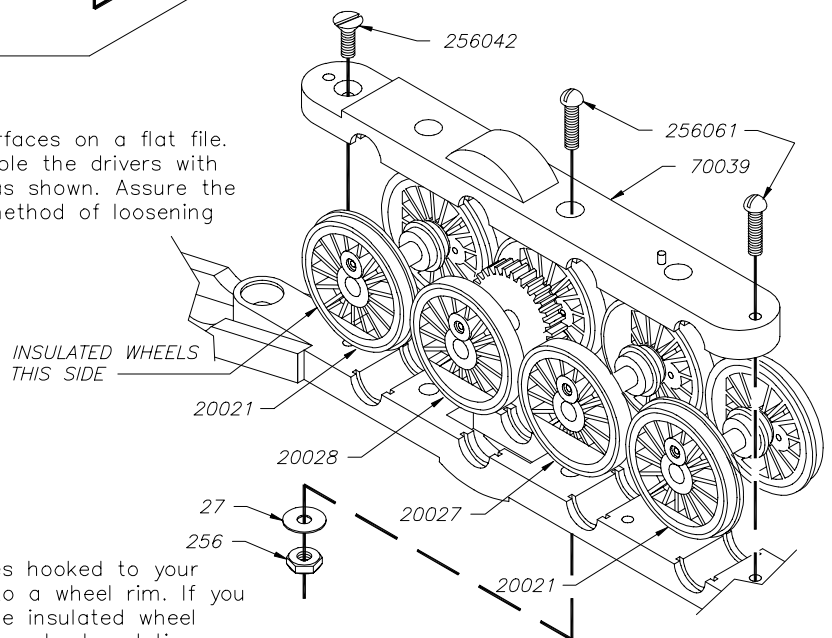

D:\100400-1

To find which wheel is insulated with two wires hooked to your power pack, touch one to the axle and one to a wheel rim. If you cause a spark that wheel is not insulated. The insulated wheel has a thin gray strip of insulation between the wheel and tire.

STEP #3a

Assemble draw bar as shown.

TO SEAT BEARINGS, SUPPORT FRAME ON FINGERS NOT A SOLID BLOCK. PLACE A 5/16 NUT OVER BEARINGS AND STRIKE A SHARP BLOW USING A TACK HAMMER OR OTHER LIGHT HAMMER. REPEAT OVER EACH AXLE UNTIL EACH DRIVER SPINS FREELY. DO NOT PROCEED ANY FURTHER UNTIL ALL DRIVERS WILL SPIN FREELY.

INSULATED DRIVERS ON THIS SIDE OF FRAME.

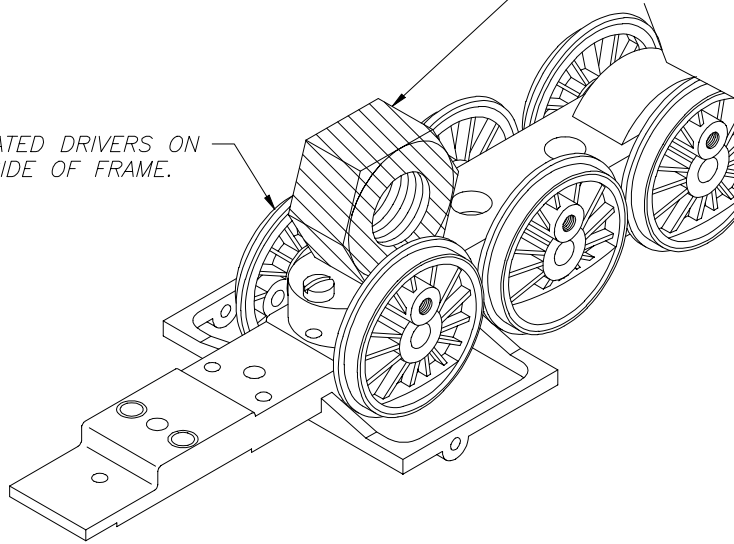

STEP #4

Assemble side rods to drivers.

Assure wheels spin freely.

If binding occurs ream holes in side rods until eliminated.

Oil lightly.

WHEELS MUST SPIN ABSOLUTELY FREE.

Subkit 100401

FULL SIZE



80004



805



873

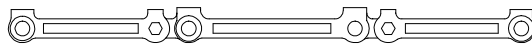
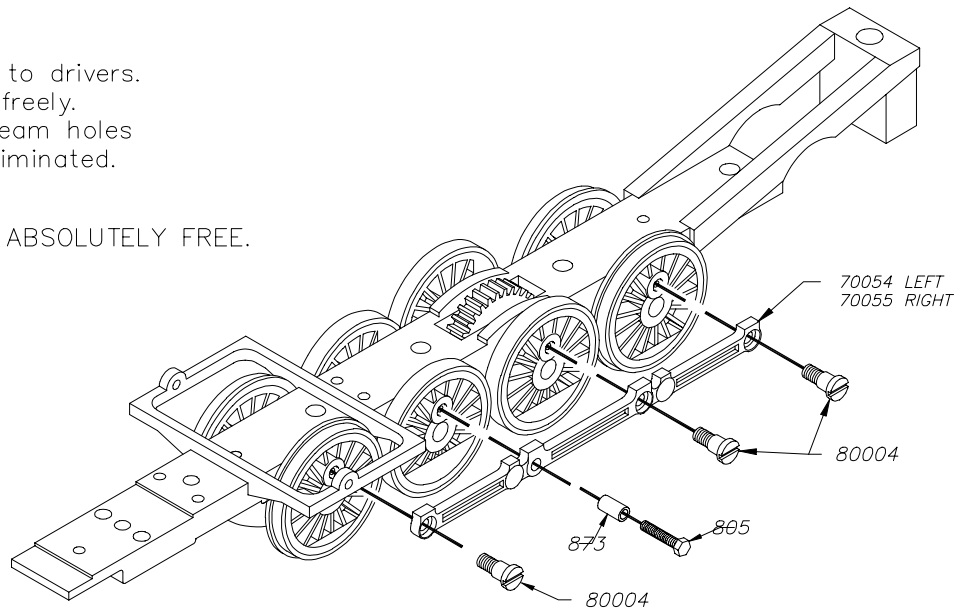

70055 RIGHT

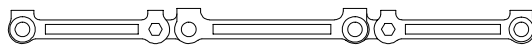

70054 LEFT

STEP #5

Assemble cylinders, crossheads & main rods to mechanism. Crossheads should slide freely on guide rods. There must not be any binding in mechanism.

Subkit 100401, 100403

FULL SIZE

		
806	80006	875

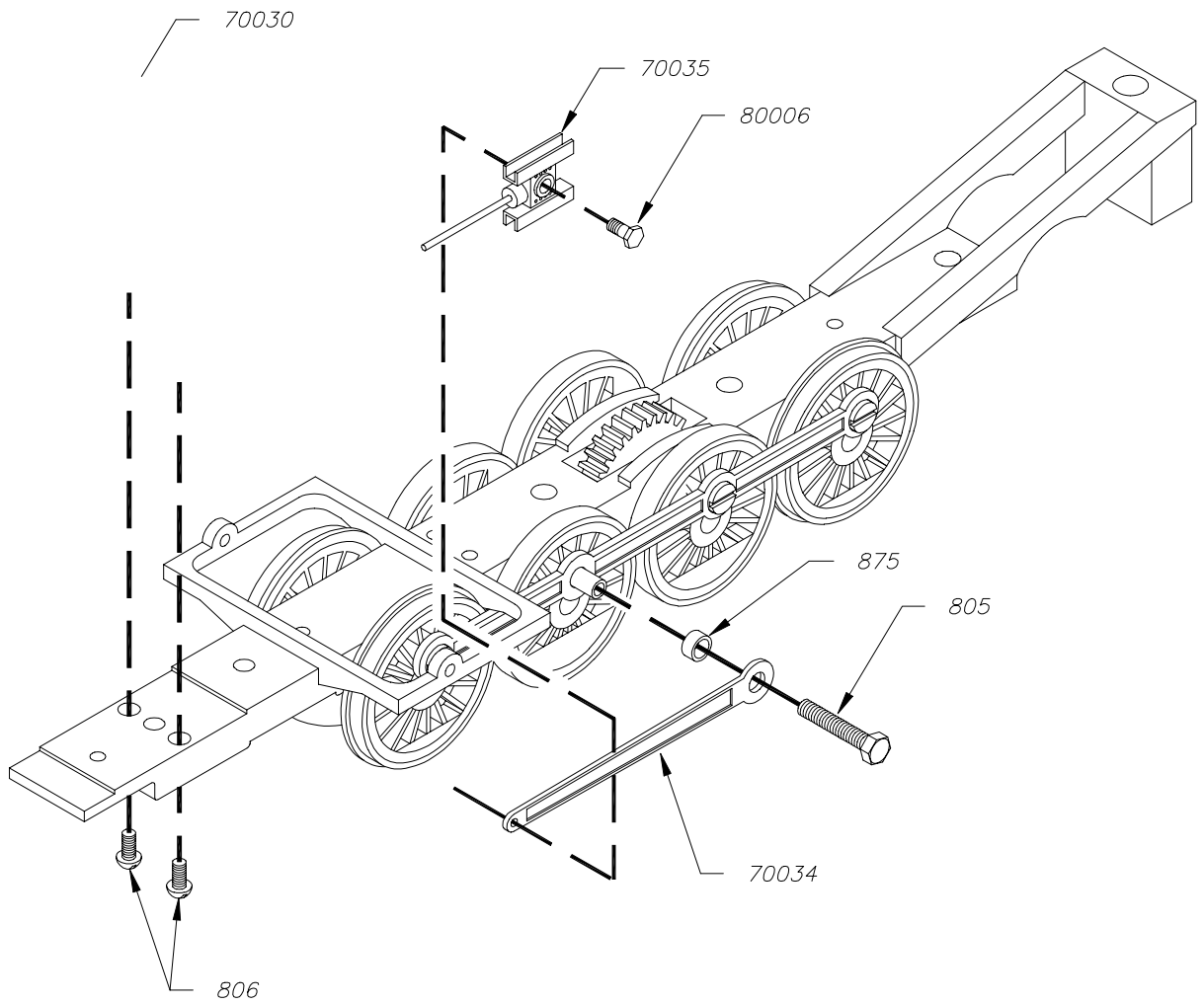

STEP #6

Assemble valve gear.

Subkit 100405



FULL SIZE

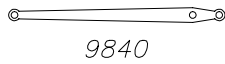

9840



60005

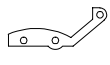

70036

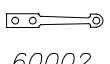

60002

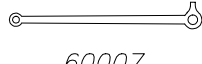

60007

SET RIVETOOL WITH CENTER POINT IN HOLE IN END OF RIVET. TAP WITH LIGHT HAMMER UNTIL RIVET IS PROPERLY FLARED. BE CAREFUL NOT TO MAKE JOINT TOO TIGHT.

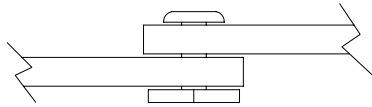

SIDE VIEW OF RIVET SHOWN 10X SIZE NOTE CLEARANCE

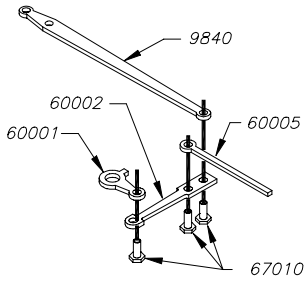
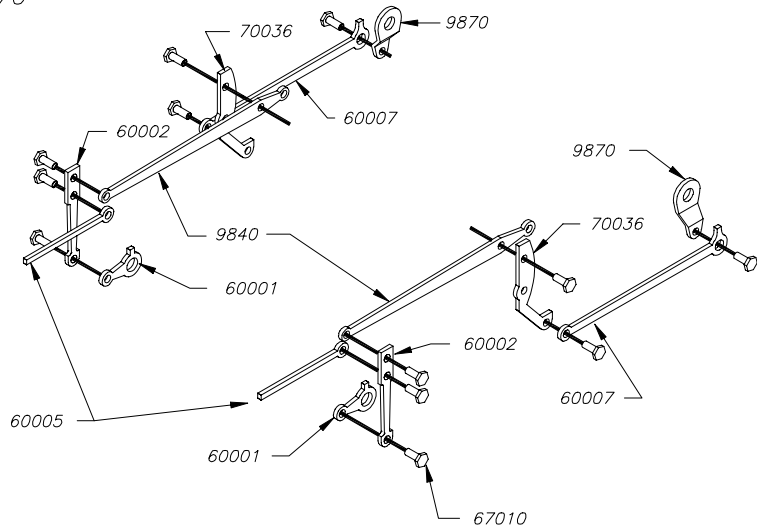

LEFT SIDE FRONT UNIT

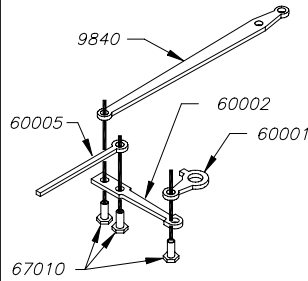

RIGHT SIDE FRONT UNIT

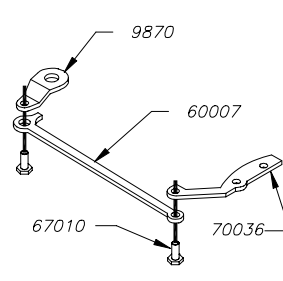

LEFT SIDE REAR UNIT

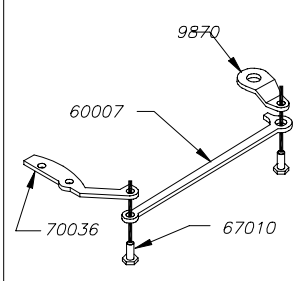

RIGHT SIDE REAR UNIT

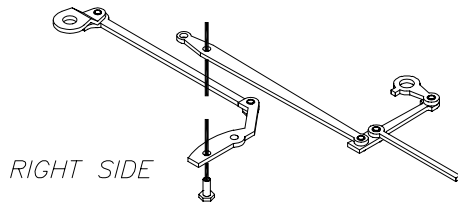

RIGHT SIDE

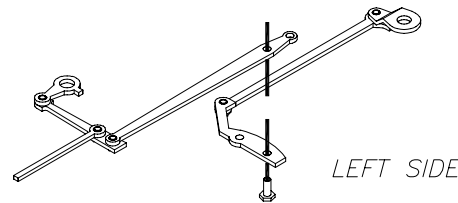

LEFT SIDE

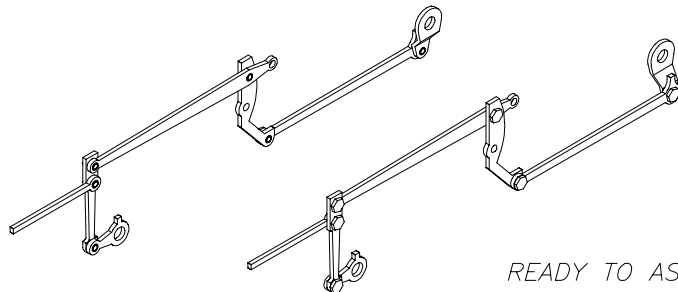

READY TO ASSEMBLE TO HANGER

STEP #6a

Install valve gear on mechanism.
Time valve gear as shown.
Mechanism at this point must be absolutely free of any binds before proceeding any further with assembly. Do not mount motor until it is free running.

Subkit 100405

FULL SIZE

80006

805

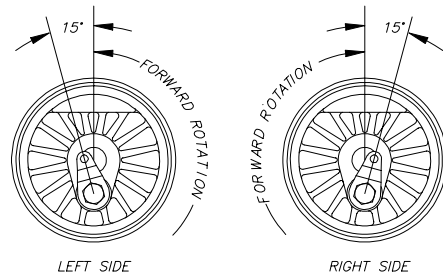
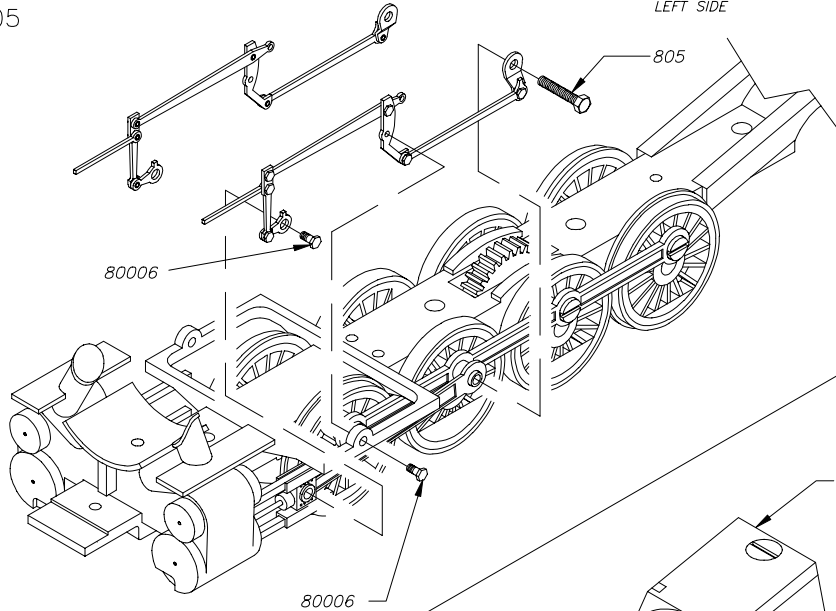

STEP #7

Install motor. Check gear mesh as shown in drawing. Adjust mesh using #29 washers.

Subkit 100405

FULL SIZE

256061

440032

256

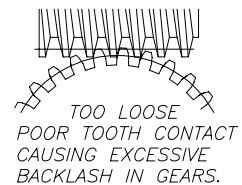
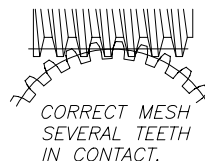
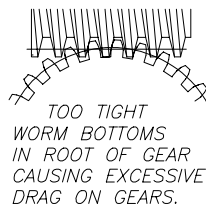
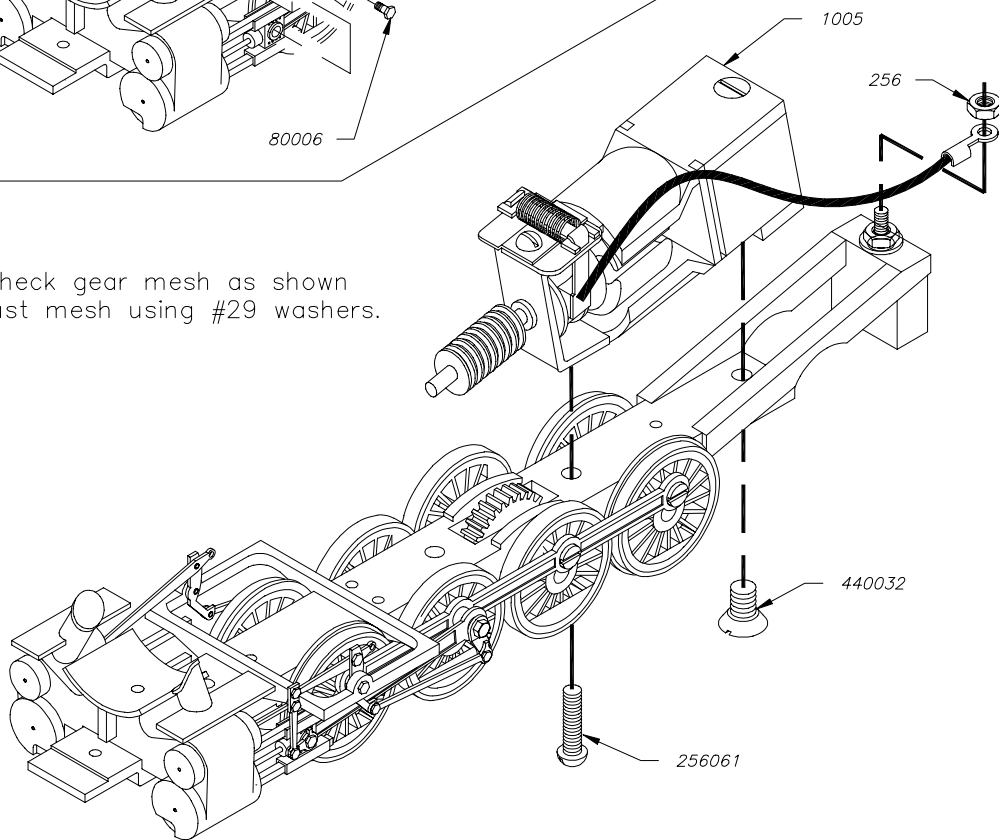

STEP #8

Assemble trailing truck.

Subkit 100407

FULL SIZE

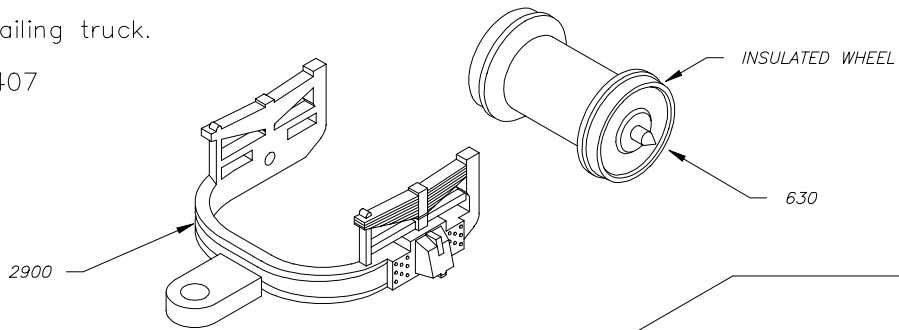

Spread frame slightly and snap wheels in place.

STEP #9

Install trailing truck to mechanism.

Subkit 100407

FULL SIZE



325

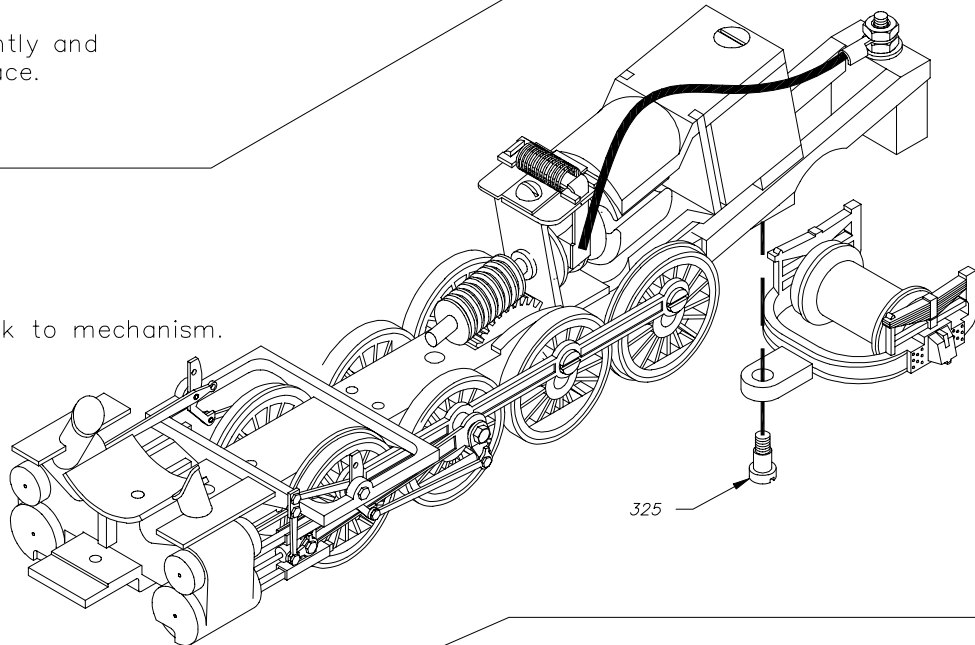

STEP #10

Glue weights inside boiler.
Assemble boiler backhead, cab floor,
air tank & cab back plate.

Subkit 100406

FULL SIZE



809

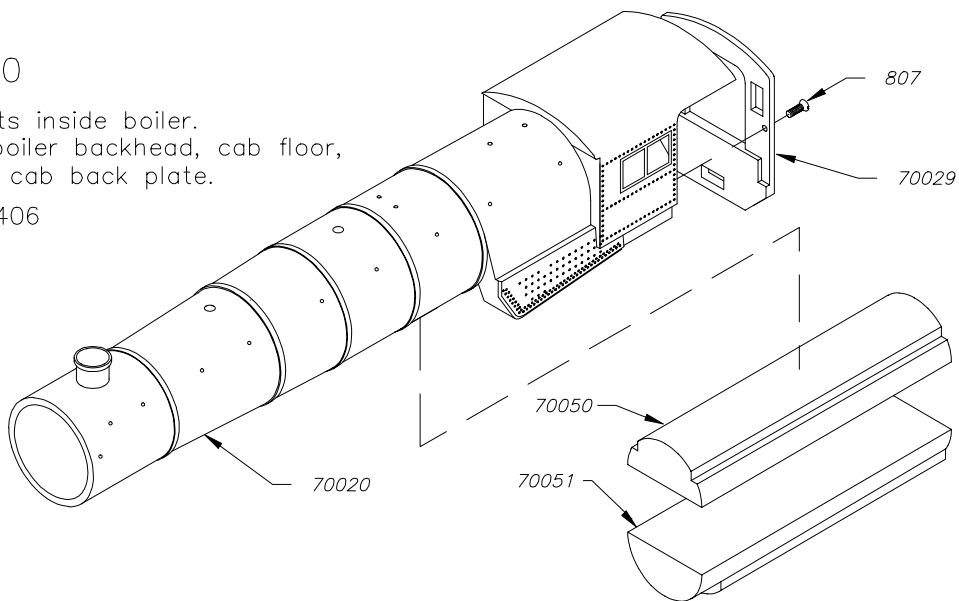

STEP #11

Assemble lead truck
Keep insulated wheels on same side.

Subkit 100404

FULL SIZE



2623

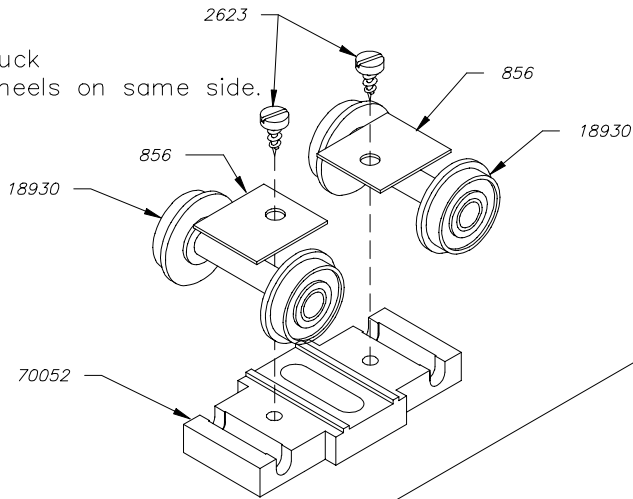

STEP #12

Assemble boiler & lead truck
to mechanism.

Subkit 100404

FULL SIZE

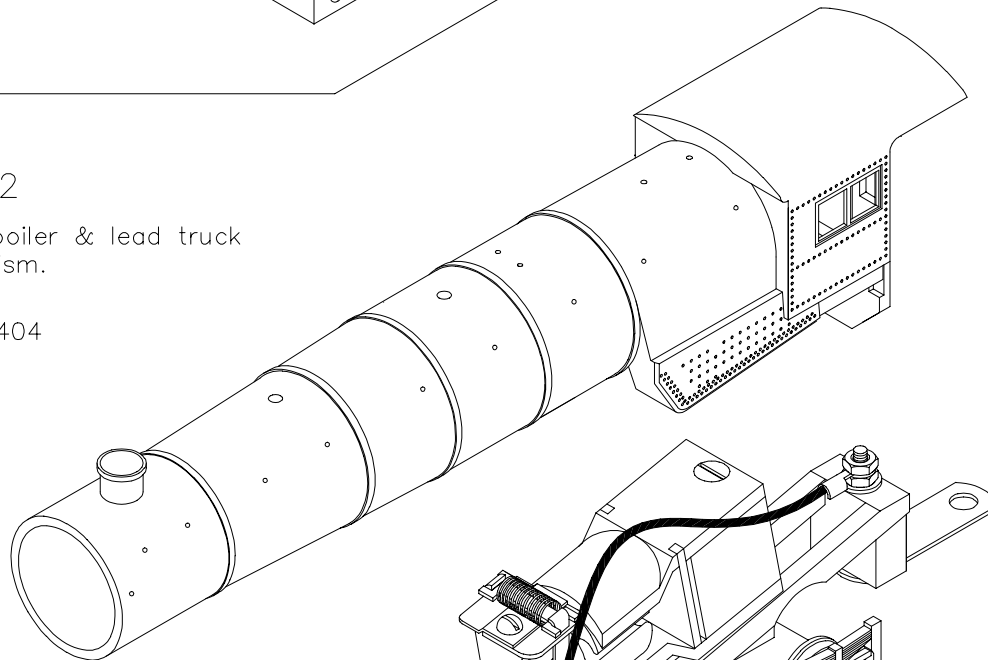

5203



25



256162



70033

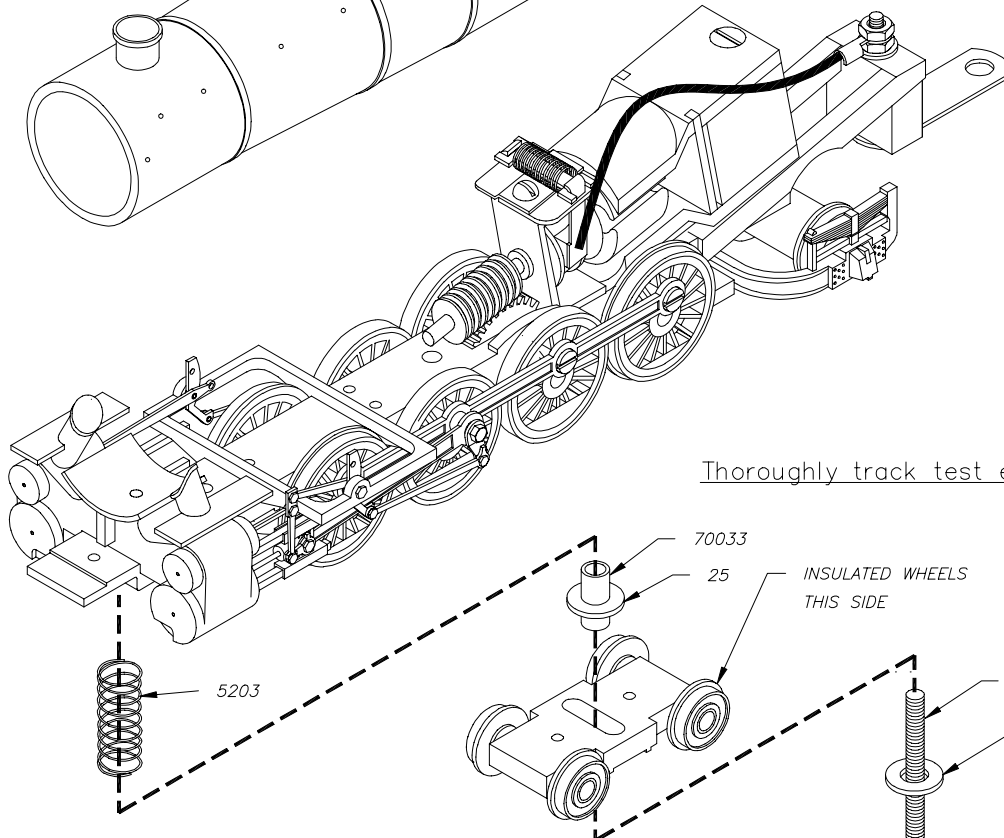

Thoroughly track test engine.

STEP #13

Assemble tender.



256032



325



256041

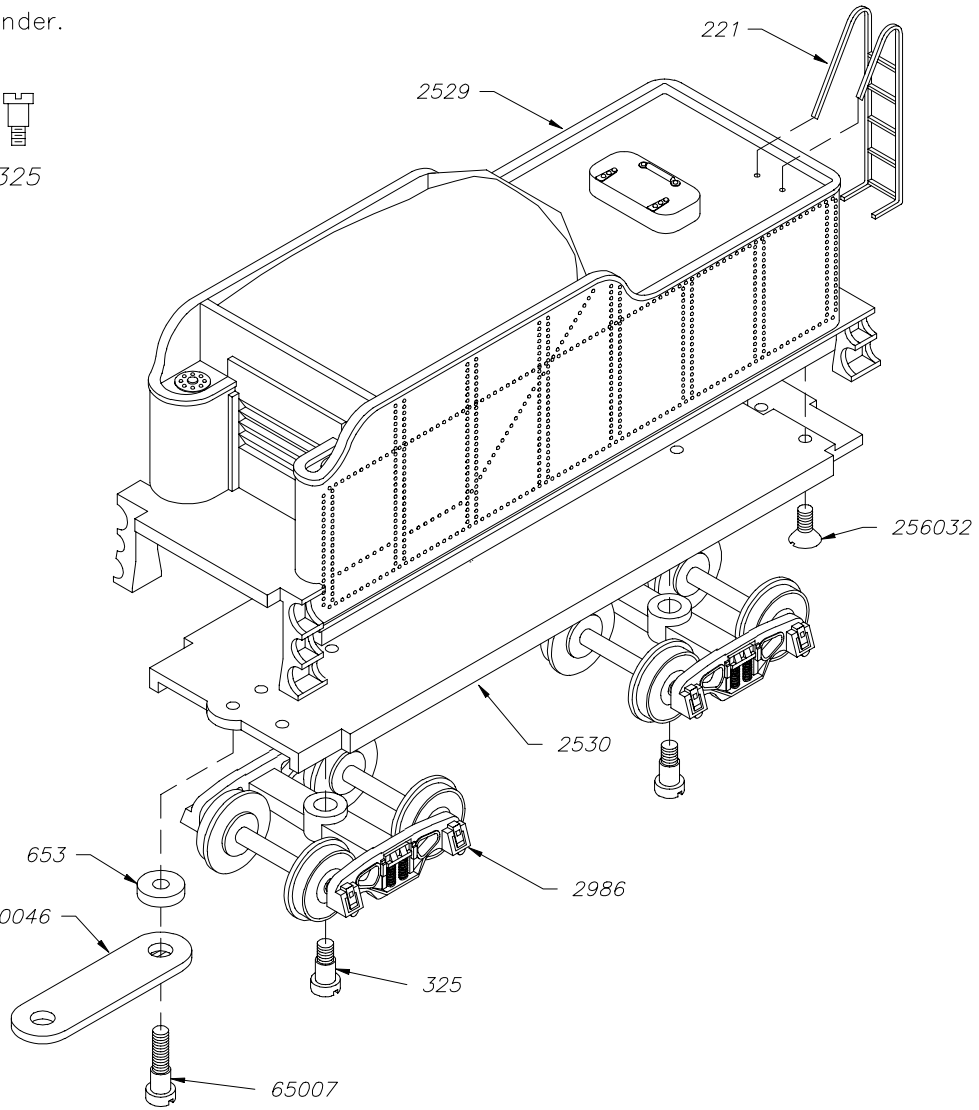

FIGURE 1



FIGURE 2



FIGURE 3



FIGURE 4



FIGURE 5

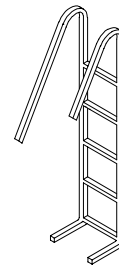

FIGURE 6

(SCALE: FULL SIZE)

STEP #14

After thoroughly track testing engine remove boiler from mechanism
remove boiler from mechanism
and detail right side of boiler.

Subkit 100456
& 100459

FULL SIZE

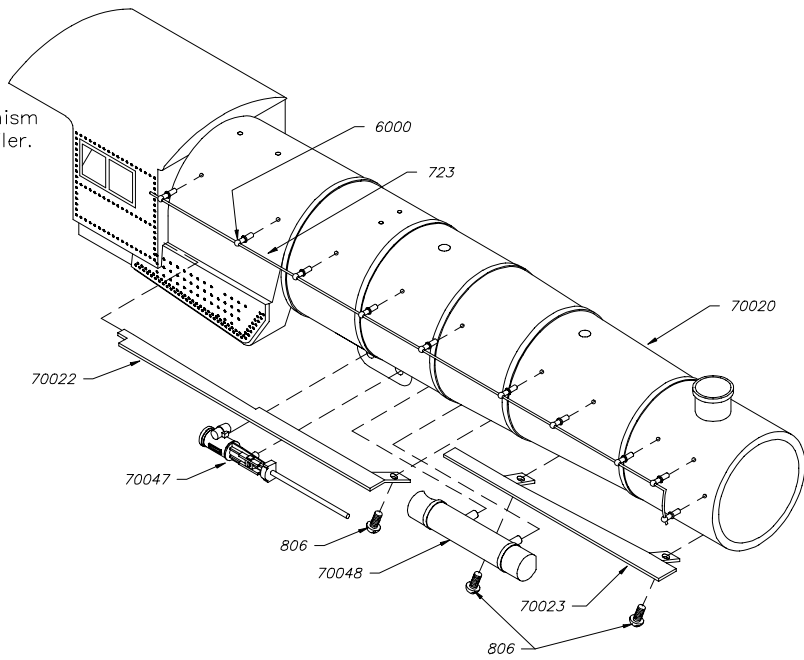

STEP #15

Detail left
side of boiler.

Subkit 100456
& 100459

FULL SIZE

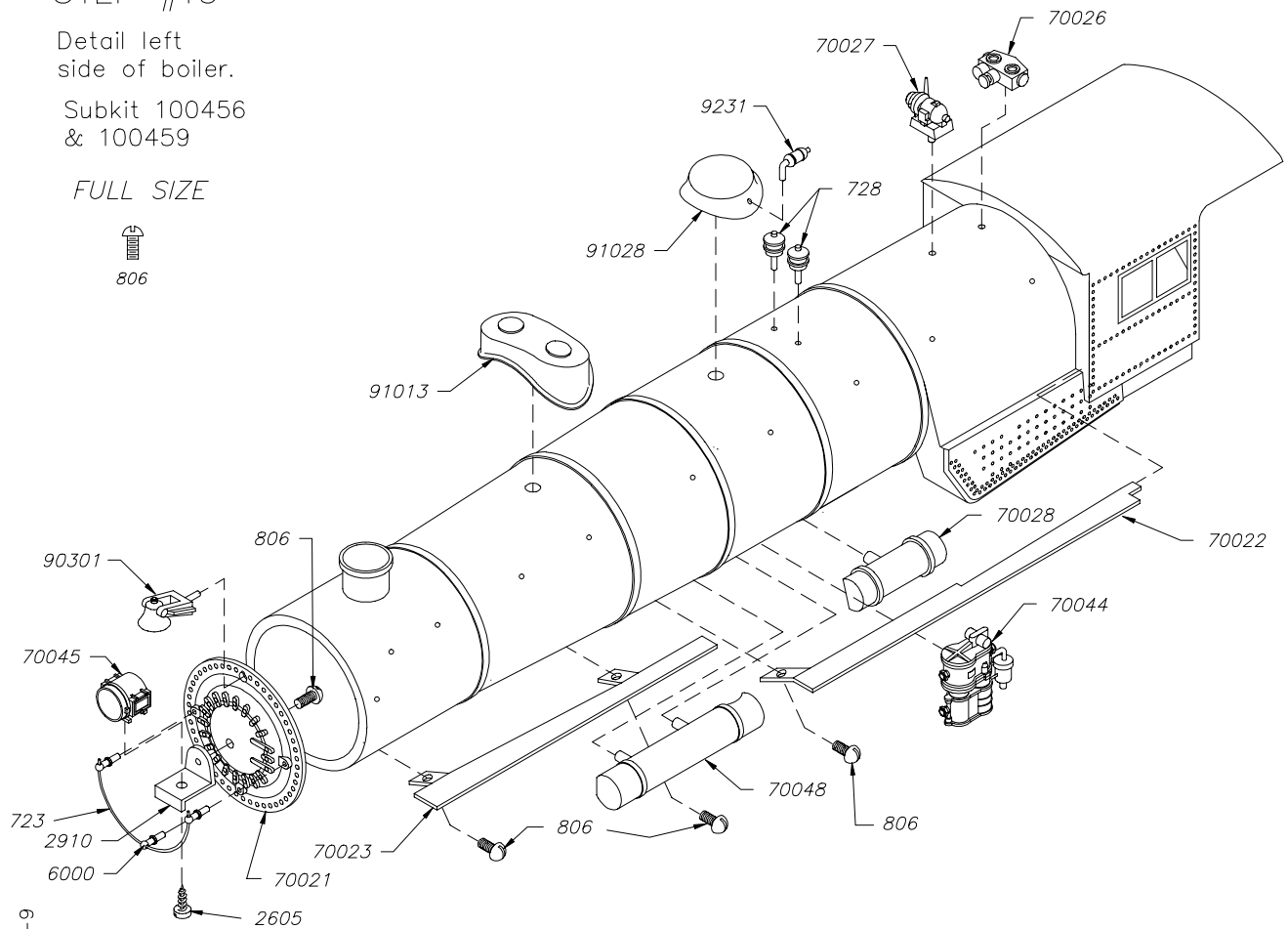

100400-9

STEP #16

Install pilot and steps on mechanism.

DO NOT PAINT BOILER AT THIS TIME
TEST RUN ENGINE BEFORE PAINTING.

Subkit 100406

FULL SIZE



256032

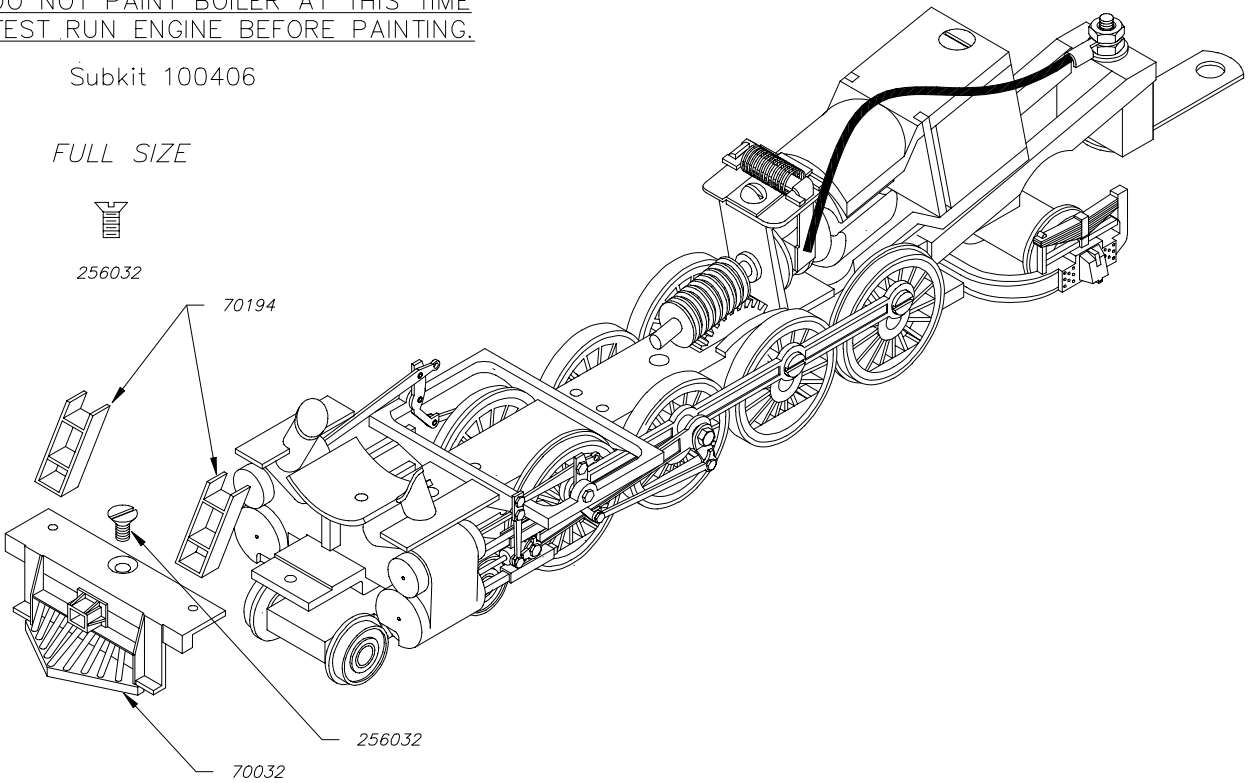

STEP #17

Test run engine.
Disassemble.
Clean, paint and reassemble including boiler.
ENJOY.

Miscellaneous Building Tips

TIP 1: Painting Metal

You may want to superdetail your loco before painting.

We suggest that you do not paint your loco until it is thoroughly track tested as disassembly and handling generally ruins a paint job. Take your locomotive apart so that the various parts may be painted without getting paint on moving parts.

Valve gear, side rods, bearings, pony truck, etc. will not operate properly if paint gets into the joints of moving parts.

Parts to be painted should be degreased with a solvent like paint thinner and pickled in acetic acid solution (vinegar) or oxalic acid solution (5%) for a few minutes before applying paint.

DO NOT USE THIS VINEGAR FOR COOKING OR EATING.

Rinse with clean water. Do not handle the surfaces to

be painted. CAUTION: Do not immerse wheels, underframe or cover plate in acid solution or cleaners. Brush cleaner and acid solutions on metal frames of lead and trailing trucks and on underframe surfaces to be painted (NOT ON WHEELS, AXLES OR BEARING SLOTS). Drivers are pre-blackened and can be touched up, after removing flash, without using cleaner or acid. I recommend a glossy paint be used (PRR locos were painted Brunswick Green). Apply a smooth, uniform coat of good grade model railroad paint. I like to spray paint my models. Work carefully to avoid piling up paint around small details.

Painting exposed surfaces of main frame will add to final appearance of model, but be careful not to get paint in any bearings.

TIP 2: Hex Head Wrench (Cheap and Easy)

Go to your hardware store and buy Socket Head Cap Screws or Set Screws in many different sizes. They have the hex shape machined in the head and will work for tightening hex head screws.

TIP 3: Soldering Tips

Wear Eye Protection

First be sure everything is clean.

Put flux on both parts. Hold together and place solder iron at joint. The solder will flow to the hot area. Solder should not form a ball. This indicates the area was not hot enough. To tin your soldering iron so that solder will stick to it.

When cold clean the tip with a file. Put a little flux on tip. Turn on iron and apply solder to the tip as soon as it gets hot.

If this does not work. Clean the tip while hot and dip tip in a drop of flux (while hot) and immediately put solder on tip.

TIP 4: Cleaning A File When the Grooves Fill

When filing parts, the grooves in a file will fill with the metal you are filing.

This metal can be removed quickly by using a small piece of thin steel (1/16 to 1/8" thick) and sliding the steel on the file in the direction of the grooves. The chips that remain can be removed by sliding a sharp knife in each groove. This may take awhile to clean each groove. I do this only as a last resort. To keep most of the chips from sticking while you file, apply a thin oil to the file before filing.

TIP 5: Drilling Small Holes

To drill metal with small drills it is best to use powered tools. Dremel tool or a small drill press. Hand drilling with a pin vise will work but is much slower. You must drill straight. Drills do not bend they break. Use a lubricant on the drill. Cutting oil is best, but you can use a bar of Ivory Soap. Put the lube on the drill before starting. I recommend peck drilling.

(Drill about 1 or 2 times the diameter of the drill and remove the drill from the hole. Clean off the chips. Lube the drill and repeat.)

Take your time. It is very important to clean the chips from the flutes of the drill. When the flutes fill with chips the drill will break.

The smaller the drill the more you need to peck drill.

TIP 6: Tapping a Drilled Hole

First be sure your hole is the proper size.

00-90 Taps #60

0-80 Taps #55

2-56 Tap #49

4-40 Tap #43

These drill sizes are one size larger than the charts.

We feel they work very well for steel, brass and zinc.

You must tap straight. Taps do not bend they break.

Use a lubricant on the tap. Cutting oil is best but you can use a bar of Ivory Soap.

Put the lube on the tap before starting.

Turn in tap to get it started (1 or 2 turns). Back off 1/2 turn. This breaks the chips that form when tapping.

Repeat above. As the hole gets deeper you will have to back off the tap more often. If you are tapping a very deep hole you will have to back off the tap after as little as 1/2 turn